

Installation and Maintenance Manual

INCLIN 6000 neo

Serial nº	Voltage
-----	-----

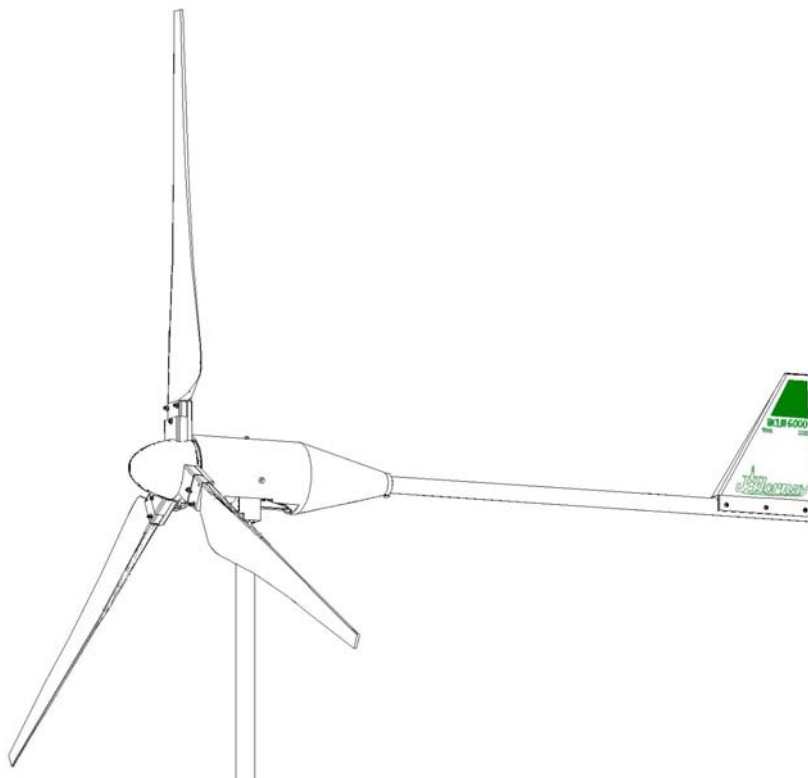

Juan y David Bornay, S.L.

Paraje Ameraors, s/n
Apartado de Correos 116
03420 Castalla (Alicante)
España

Tel. (34) 965 560 025
Fax (34) 965 560 752

<http://www.bornay.com>
bornay@bornay.com

Index

<i>Index</i>	2
<i>Welcome to the world of the wind</i>	3
<i>Wind Turbine components</i>	4
<i>Technical data</i>	5
<i>Site for the Wind Turbine</i>	6
<i>The Tower</i>	6
<i>Installing the Wind Turbine</i>	7
<i>Regulator</i>	7
<i>Electric connection</i>	8
<i>Installing the Wind Turbine</i>	10
<i>Cautions</i>	12
<i>Maintenance</i>	13
<i>Annex</i>	15
<i>Annex</i>	16
<i>Landscape and objects that influence on wind turbines</i>	17
<i>Warranty</i>	18

Welcome to the world of the wind

Interesting information:

In this manual you will find all the information needed to install and maintain your wind turbine. We strongly recommend you read this manual thoroughly and understand it before beginning assembly.

At several points in this manual you will find special notes highlighted. This notes are to be taken with special care because have critical importance, please, pay special attention to those points marked as the following example notices:

CAUTION:
Important details for the right functioning of the system.

WARNING:
Hazards or unsafe actions that could cause an injury to your system or yourself.

Identification.

Each wind turbine is labeled with its model, voltage and serial number data as it follows:

Manual: Labeled on the cover of this manual and in the guarantee fee page.

Alternator: A blue label, on the bridge holding the external body, shows the wind turbine model and its voltage. On the tail tube, there is a white label with the serial number of the machine.
Externally, no need to remove the protective framework, you will find on the collector brushes lid, the model and voltage of the wind turbine.

Regulator: On the right side of the control box, there is a sticker indicating the characteristics, regulator model, wind turbine model, voltage, serial number and tested date.

Other interesting data.

Here you can write down other interesting data about your installation:

Wind Turbine components

Next to this documentation, in the original box, you will find the components listed below. Some items may already assembled:

- 1 Tail
- 1 Tail tube
- 1 Nacelle
- 1 Alternator
- 1 Hub
- 3 Blades
- 1 Frontal Cone
- 1 Set of bolts
- 1 Fixation plate
- 1 Control Box.

Exploited view of the wind turbine:

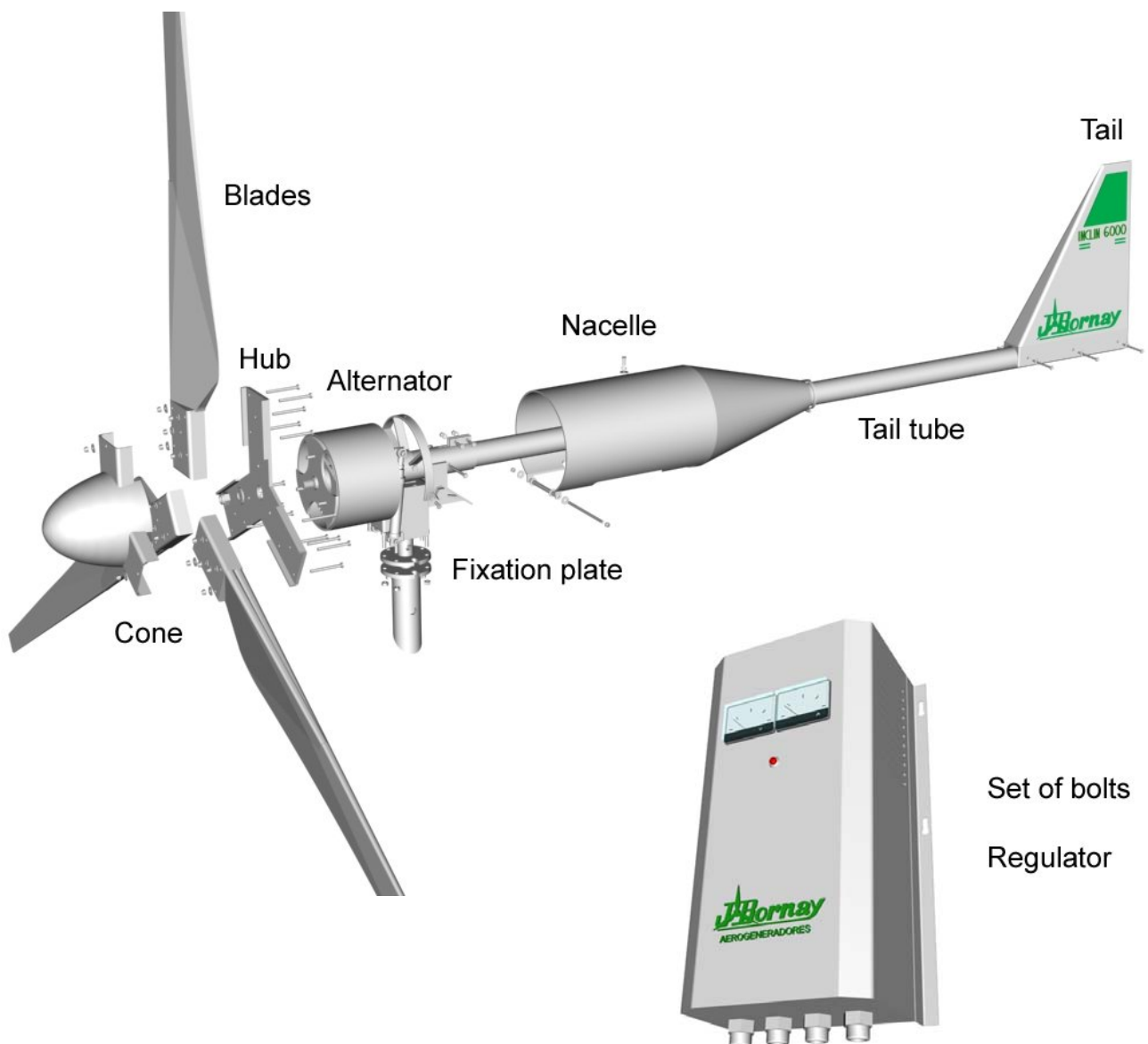

Technical data

INCLIN **250** **600** **1500 neo** **3000 neo** **6000 neo**

ROTOR:

BLADE NUMBER	2	2	2	2	3
DIAMETER (m)	1,35	2	2,86	4	4
MATERIAL	Nylon	Fiber glass / carbon			

ELECTRICAL SYSTEM:

TYPE	Three phases permanent magnet alternator				
MAGNETS	Ferrite		Neodymium		
RATED POWER	250 W	600 W	1500 W	3000 W	6000 W
VOLTAGE (V)	12 / 24 / 48 v		24 / 48 / 120 / 300 v		48 / 300 v
Regulator and Full Wave Rectifier box and Volts and Watts Display.					

PERFORMANCE - WIND SPEED:

CUT IN wind speed	3 m/s	3'5 m/s	3'5 m/s	3'5 m/s	3'5 m/s
RATED wind speed	11 m/s	11 m/s	12 m/s	12 m/s	12 m/s
AUTOM BREAK ws	13 m/s	13 m/s	14 m/s	14 m/s	14 m/s

W

Calculated Power Curve - Inclin 6000



Site for the Wind Turbine

The energy we can take from the wind is proportional to the cube of its speed. This basically means, that when the wind doubles its speed, the power we can produce is up to eight times higher.

Therefore, the best site to install a wind turbine will be a place where it is exposed to the most constant and highest wind speed possible. The wind speed depends enormously on the landscape the air moves over. In almost all locations the wind speed increases, as you get higher off the ground; vegetation, landscape, nearby buildings, etc. stop the wind and produce turbulences.

The best place for a wind machine, is an **obstructions free area, and the highest possible.**

The Tower

It is recommended to install the windmill on an independent tower not next to the house to avoid turbulences.

The anchoring of the tower will depend on the kind of tower you will be using. The foundation for the self-standing towers is very important, and for the tilt-up tower is just to avoid it sinking on the ground. For both cases, check that at all moment the tower remains totally vertical.

If your tower is not strong enough, you must reinforce it using guy ropes. If the ground is not strong, remember to use a correct size for basements. Check that at all time your tower remains perfectly vertical.

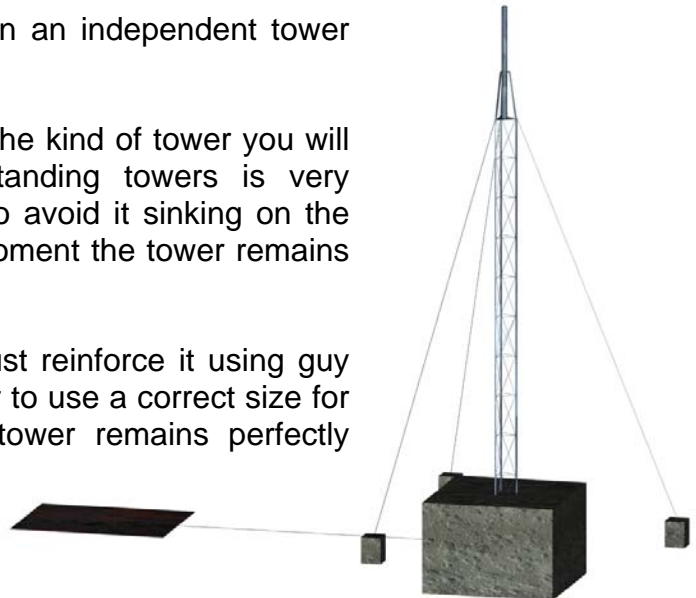

The guy ropes take all the bending moment on the tower. They, therefore must be 6-10 mm diameter steel cables. Attach the guy ropes the highest on the tower but **always beneath blades diameter.**

Grounding the tower will provide static and lightning protection for the system. This can be made by driving cooper wire into the ground near the tower base and connecting it to the tower with wire.

You must absolutely make sure that no object could possibly reach the blades, and that any other parts of the wind turbine touch any other moving part.

Allow a minimum distance of 20 cm between the blades and the tower.

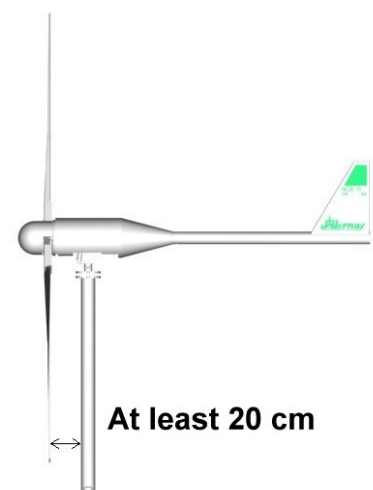

CAUTION:

The wind turbine must be able to turn 360° freely with no obstacles in its way.

WARNING:

Objects contacting moving blades may cause damage and/or imbalance, which can lead to system instability and cause major problems to the wind turbine.

Installing the Wind Turbine

To easily install the wind turbine on the tower, a bracket and pulley system should be used.

This system must securely attached to the tower, with the pulley on top. Usin this method, the turbine can be hoisted up and secured while the electirical connection is completed and the turbine is fitted to the tower.

Make sure all of the other electrical connections are completed before attempting to electrically connect the turbine to the system.



Regulator

The regulator is protects the batteries from high voltage. Any electric generator that can over exceed the batteries voltage, requires a charge regulator. The correct use of the proper regulator is critical to good perfomance and long life of the battery system.

The regulator continually monitors the battery voltage and controls the current through the batteries. It allows the optimum charge to the batteries when they are low and diverts the charge to a dump load when they are fully charged. This dump load is installed within the regulator and can be fitted with an optional water heater output.

The regulators J.Bornay wind turbines use, have been specially designed to work with our machines, and solar panels in hybrid cases.

The regulator is provided with the following connection switches:

- Three phases input from the wind turbine
- Solar panels input +/- (Optional)
- Batteries output +/-
- Water heater output (Optional)



All our regulators are equipped with a red led. This led will be on when the batteries are fully charged and the electricity is being driven to the dump load. They are equipped, as well, with a voltmeter and an amp meter to measure the electricity that is being produced at all times.

Do not connect any other electric element between the windturbine and the regulator or between the regulator and the batteries, serious damage could occur.

On the left side of the regulator, there is a break switch. This switch short-circuits the alternator increasing the torque required to turn the rotor, thus slowing the turbine down. When this happens, the torque to make the alternator turn is much higher, this acts as a brake.

In high wind speeds, the blades turn very fast, the braking force of the brake switch may not immediately stop the blades of the turbine. If it continues rotating, turn the brake switch on and off repeatedly until the blades stop. Each time the switch is activated, the blades will slow until the force of the brake sufficient enough to lock the blades in position. At this point the turbine will not start until we switch the break off.

CAUTION:
In strong winds, stop the wind turbine, by switching on and off the brake several times.

WARNING:
Never force the rotation of the turbine while the brake switch is on.

Electric connection

If an external load is going to be used, connect the load where indicated before continuing with the rest of the connection. If not, the regulator is present with an internal load, so no changes need to be made.

If the system will be used in conjunction with solar collectors, these must also be connected electrically prior to connecting the regulator and the battery. The regulator will be marked as a HYBRID REGULATOR on the side and will specify the maximum allowable amp rating for the Solar collectors that can be connected. **Never invert the polarity of the Solar collector cables to the regulator and never connect collectors which exceed the maximum amp rating of the regulator.**

Regulator to Battery Connection:

First, connect the positive and negative cables from the battery to the corresponding inputs on the regulator box.

Next, connect, the three cables from the turbine. The electricity from the wind turbine is alternating three phase, so there are no polarity issues and the cables may be placed in any order.

In order to minimize the losses in the wiring, the distance between the wind turbine and the regulation box must be as short as possible. Never more than 100 meters. Also, the regulator, batteries and inverter should be installed in the central point close to where the electricity is going to be distributed, again to reduce the electrical loss in the wiring.

The cable diameter depends on the wind turbine model and the distance to the control box, check *table 2* in the annex to calculate.

The control box has to be installed approximately 1,5 m over the ground level, and a minimum of 50 cm from the batteries to prevent contact with the gasses they produce.

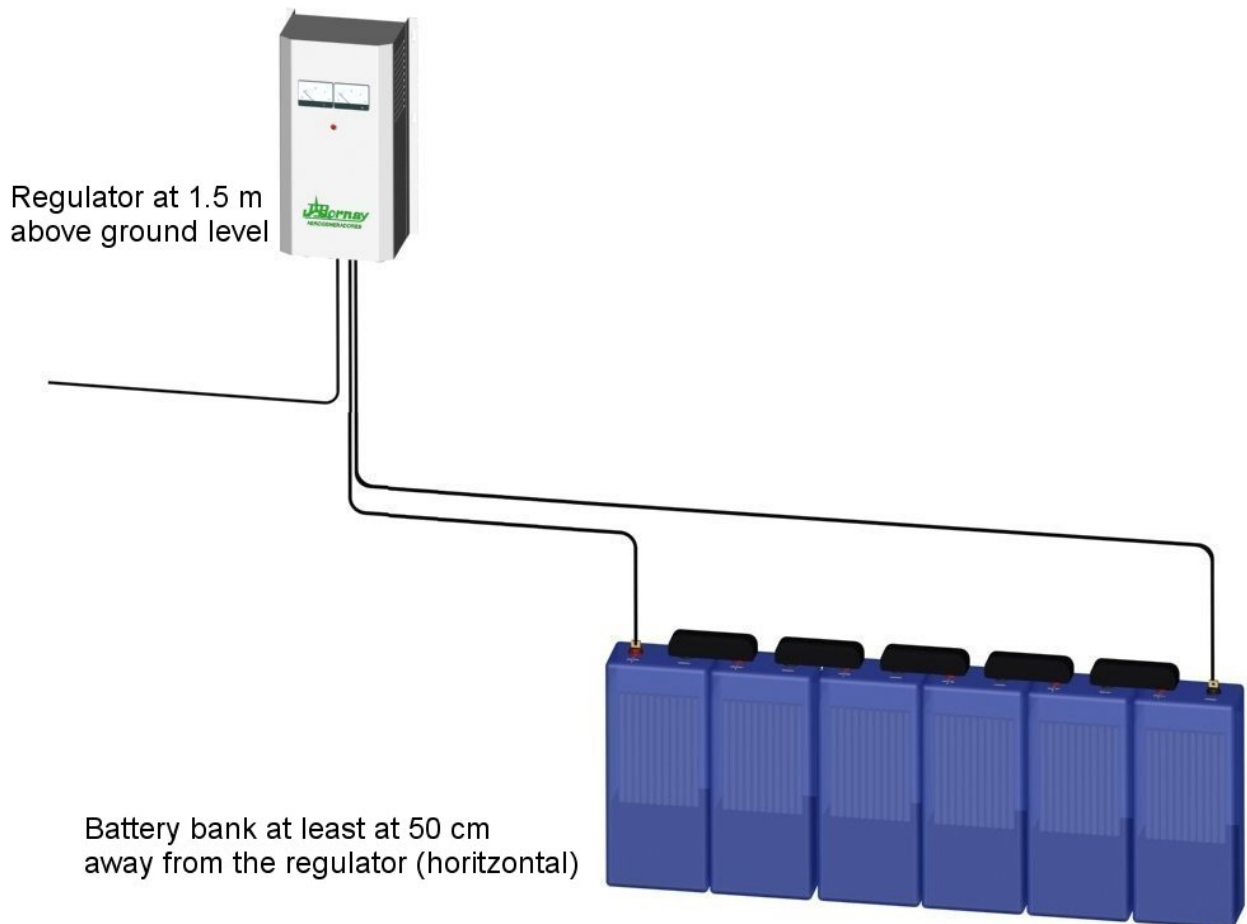

CAUTION:

Never install the blades on the wind turbine if the regulator and the batteries are not correctly connected.

WARNING:

Never invert the polarity of the batteries and always use appropriate sized cables.

In a hybrid installation, with the water heater option, the installation could be as in the next figure:

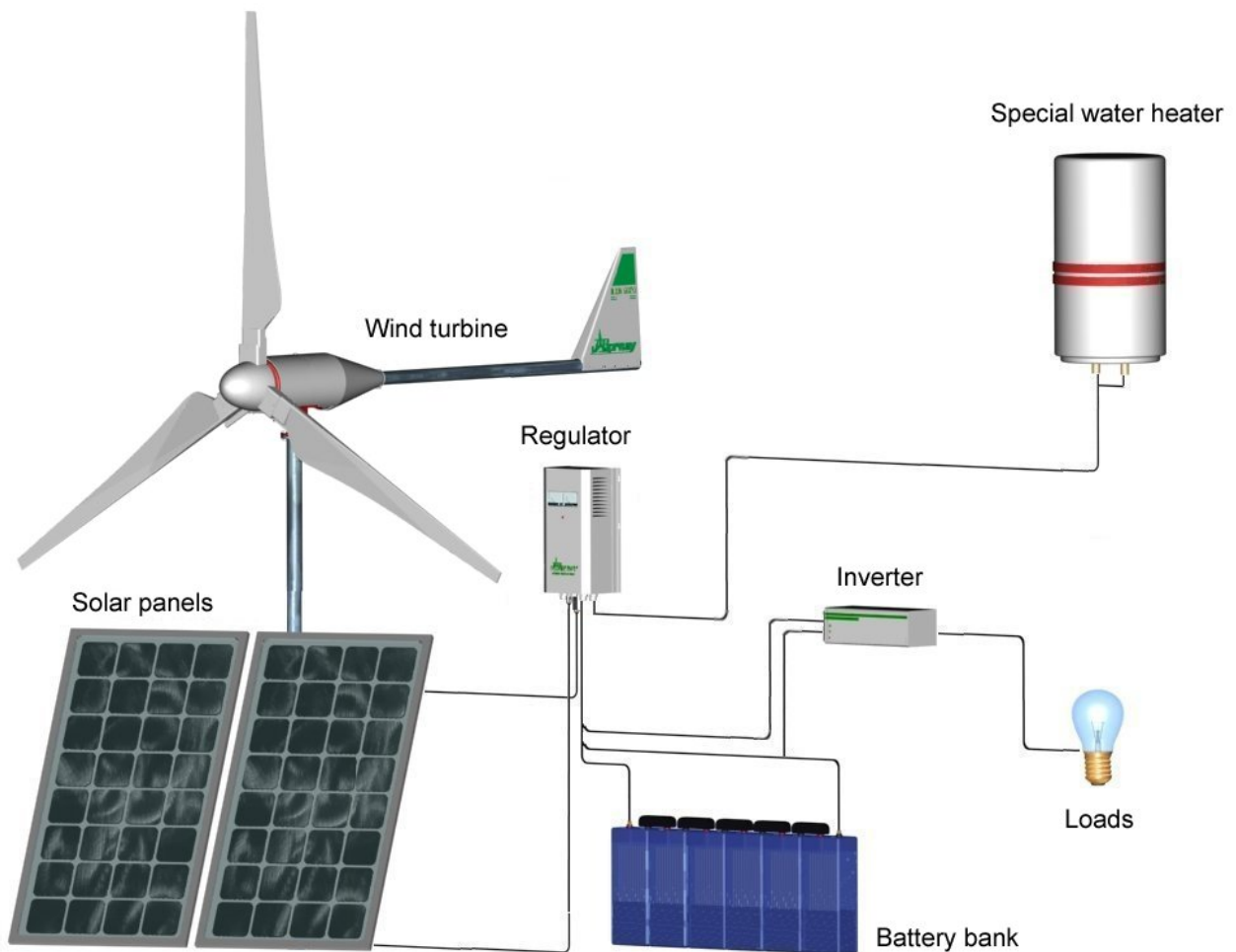

Once everything has been finally connected, including the battery bank, check if the electric installation has been done right, by running manually the alternator, and reading in the control box displays if there is an output. If there is no output, check all the connections and recheck until everything is ready to work.

Installing the Wind Turbine

Fixation plate:

This plate is attached to the tower and facilitates the installation of the turbine to the tower. Another one is assembled on the wind turbine base.

The plates are designed with slots to allow the cables pass trough with no twists. The two plates are connected using six M -10 x 40 allen bolts, M -10 washers on both faces, and six M -10 nuts. The hardware and tower plate are enclosed in an independent plastic bag in the shipment, if not mailed separately.

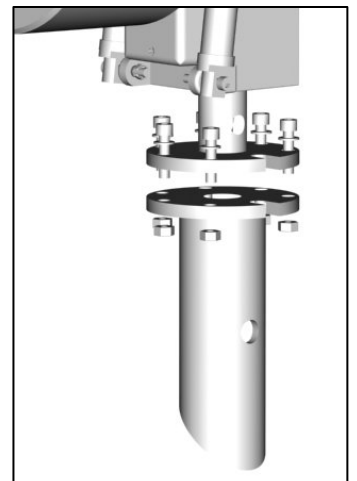

The tail is made to keep the wind turbine facing into the wind at any time.

The tail is made of two different pieces: a fiber glass vane and a steel boom. They are assembled with three M-6 x 90 bolts, six wide M-6 washers on both sides of the vane, and three M-6 self-locking nuts. This should be already assembled in the box.

Tail tube – Alternator

The tail is attached to the alternator at this point. **Before bolting the tube to the alternator, pass the body shroud through the tail tube.** (Once the tube is in place, you will not be able to install the nacelle).

This connection has two different systems to secure. One has a bolt going through the tube, and the other one is a bridle system. We first introduce the tail tube into the back side of the alternator, lining up the bolt holes on each piece. This connection uses a hexagonal M-8 x 90 bolt, with two M-8 washers, one in each side and a self-locking M-8 nut. On the top we will find the bridle. We will use two hexagonal M-8 x 30 bolts, four washers M-8, one in each side and finally two self-locking M-8 nuts.

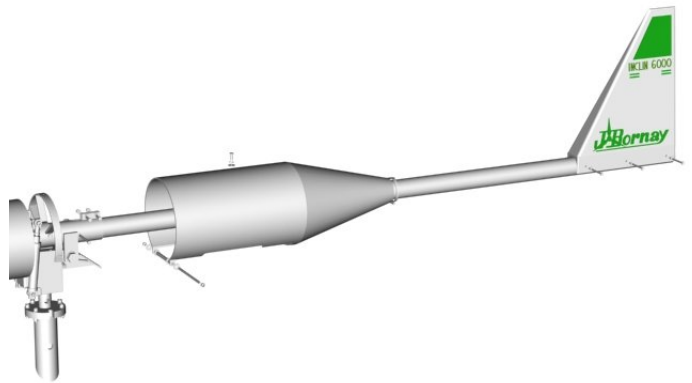

Nacelle

The nacelle protects the alternator from the external climatological agents. The nacelle is attached with five bolts; three of them are on the top, one is on the back as a bridle, and the last one on the front underneath a new bridle:

On the top of the nacelle there are three holes, to use three M-8 x 20 bolts with their correspondent wide washers M-8 and a grower washer, directly bolted to the alternator bridge. The ensemble order is: bolt, grower washer and wide washer.

The next bolt to secure is the one in the back.

At last, on the front side, using the two flanges as bridle, we put the 12 mm diameter latten tube, between and wide M-8 washers in each side (between the latten tube and the fiber glass); inside this tube, pass the M-8 x 190 threaded rod and dispose two other wide M-8 washers in each side. To secure this bridle, use two M-8 self-locking nuts (one at each side).



The blades, made out of fiberglass / reinforced carbon, are the part directly in contact with the wind. They are highly stressed. Their aerodynamics, specifically designed for **J.Bornay** wind turbines, makes the alternator turn faster or slower depending on wind speed.

To assemble them to the hub, we have to **place them with the set-off logo facing back**, this is facing the tail. The four exterior bolts, will be M-8 x 70 and the central one will be M-8 x 90 (this is used to hold the frontal cone as well). Once the bolts are all placed we put wide washers M-8 in all of them. Then on four exterior bolts, the shortest, we place self-locking nuts. In the central one, the longest, we put standard nuts. All blade bolts should be tightened with a torque wrench to 2 kg. Once this is done, retighten them to 2,5 kg; Over the two normal nuts we introduce a new wide M-8 washer. These two washers will be the support for the frontal cone, which is the next item to place. Once it is on its support, we will put a new washer and finally an self-locking M-8 nut.

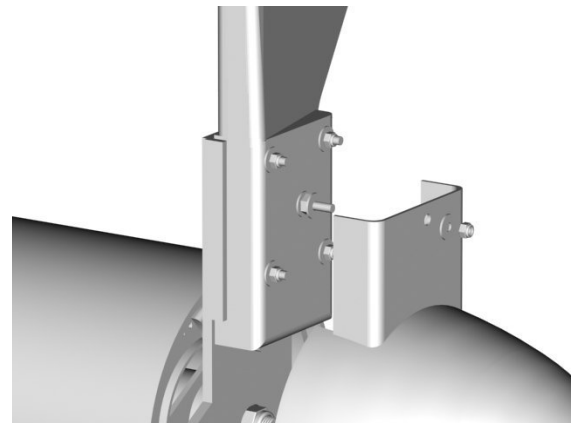
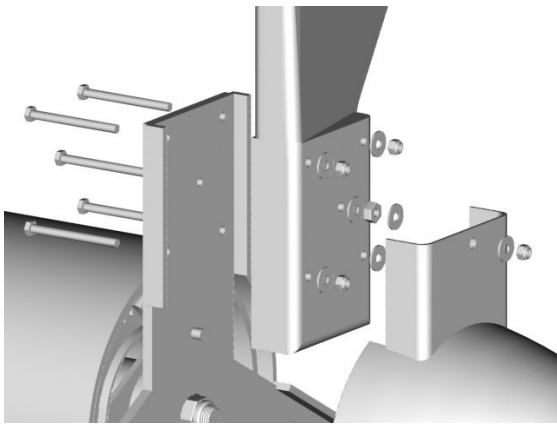

CAUTION:

Check once more there are no obstacles on the blades diameter.

WARNING:

Check the blades are rightly installed; Bornay's logo should be downwind.

Cautions

- Do not manipulate the wind turbine and its control panel on windy days.
- Do not leave the wind turbine run freely (disconnected from the batteries), this could damage the charging system. If you need to disconnect the wind turbine from the batteries, always brake it.
- With the wind turbine turning freely, the automatic breaking system does not work, that could cause irreparable damages in your wind turbine.
- Do not manipulate the loads in the regulator.
- Do not invert the polarity in any case.
- Use the appropriate wiring.

Maintenance

After the installation

One month after the installation of the wind turbine, we recommend checking that the bolts have the right torque and tightening, if necessary.

Periodic maintenance

To assure the life of your wind turbine, we recommend the following maintenance steps:

A) Every six months and during season changes, the inspection of the following points is recommended:

- Checking and reajusting the torque requiered for every bolt.
- Checking cables state.
- Visual inspection of the blades.
- Checking that the automatic breaking system works properly by inclining it manually.

B) The main parts to revise on a wind turbine are:

Bearings:

J.Bornay wind turbines are equiped with great quality sealed bearings which requiere no maintenance.

Bolts:

The bolts used in J.Bornay wind turbines are stainless steel. If a bolt is missing or in poor condition, it must be replaced right away in order to avoid any breaking or further damage.

Wiring:

All cable connections and switches must be properly checked in order to prevent any disconnection and to allow the wind turbine to run freely.

Blades:

The fiber glass / carbon reenforce blades wear a protection tape made out of abrasive polyurethane on the leading edges of the blades. After years of use, this tape may be affected by the weather conditions. If the tape is missing or partially missing, contact your local installation office to have the tape replaced. By failing to replace the tape, the life of the blade will be seriously reduced due to the strong erosion the blade is exposed to.

Shock absorber:

The wind turbine has two hydraulic shock absorbers installed that prevent abrupt thumping by promoting the fast braking and slow return to its original position.

The shock absorber has a little looseness at the beginning of its retrocession, this is normal. However, if this distance is long and oil licks, the shock absorber must be replaced.

Lubrication

Inclin wind turbines, have three moving parts:

1. The front shaft (blades-alternator) is equipped with sealed bearings and covered with lubricant. It does not need any special attention; its lubricant will last during its lifetime.
2. The yawing shaft (wind turbine-tower) is equipped with sealed bearings and covered with lubricant. It does not need any special attention; Its lubricant will last during its lifetime.
3. The Inclin shaft (alternator-yawing system) is a stainless steel tube covered with lubricant. It does not need any special attention Its lubricant will last during its lifetime.

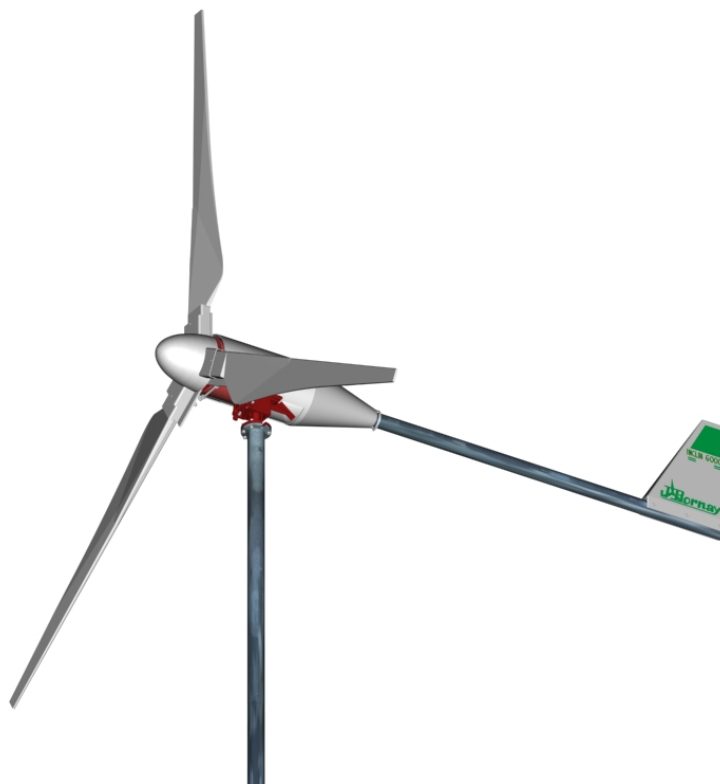

For any installation or update questions on this wind turbine or any other J.Bornay product, contact our offices at:

Juan y David Bornay, S.L.
Paraje Ameradors, s/n
P.O. Box 116
E-03420 Castalla (Alicante)
España



Telf: (+34) 96 556 0025
Fax: (+34) 96 556 0752

bornay@bornay.com
www.bornay.com

Annex

Anex 1: Beaufort's table is the international reference to classify and define the wind depending on its speed.

FUERZA	Wind speed (m/s)	Wind speed (km/h)	Denomination
0	0 - 0.5	0 - 1	Calm
1	0.6 - 1.7	2 - 6	Light air
2	1.8 - 3.3	7 - 12	Light breeze
3	3.4 - 5.2	13 - 18	Gentle breeze
4	5.3 - 7.4	19 - 26	Moderate breeze
5	5.7 - 9.8	27 - 35	Fresh breeze
6	9.9 - 10.4	36 - 44	Strong breeze
7	12.5 - 15.2	45 - 54	Near gale
8	15.3 - 18.2	55 - 65	Gale
9	18.3 - 21.5	66 - 77	Strong gale
10	21.6 - 25.1	78 - 90	Storm
11	25.2 - 29	91 - 104	Violent storm
12	Más de 29	Más de 104	Hurricane

Anex 2: Wiring dimensions for the cable coming down from the wind turbine to the control box.

Maximal amps per phase	Maximal amps per 3 phases	Minimum recommended length (mm)		
		Up to 30 m	Up to 60 m	Up to 90 m
42	126	3 x 16	3 x 16	3 x 25
21	63	3 x 10	3 x 10	3 x 16
16	48	3 x 10	3 x 10	3 x 10
11	33	3 x 6	3 x 6	3 x 6
5	15	3 x 4	3 x 4	3 x 6

Annex

Anexe 3: Declaration of conformity.



Juan y David Bornay, S.L.

Paraje Ameradors, s/n
Apartado de Correos 116
03420 CASTALLA (Alicante) España

Tel. (+34) 965 560 025
Fax (+34) 965 560 752

<http://www.bornay.com>
e-mail: bornay@bornay.com

DECLARACIÓN DE CONFORMIDAD DECLARATION OF CONFORMITY

Fecha: Junio 2001
Date: June 2001

Productos: Aerogeneradores
Products: Wind turbines

Modelos: G-60 W Inclin 1500 neo
Models: Inclin 250 Inclin 3000 neo
 Inclin 600 Inclin 6000 neo

Y accesorios:
And accessories:

Reguladores: 50, 100, 150, 150R Amp., y específicos para Inclin 6000 y Bk 12 Kw.
Regulators: 50, 100, 150, 150R Amp., and specific for Inclin 6000 and Bk 12 Kw.

Estos productos están en conformidad con las normas aplicables bajo las directiva de la U.E.:
These products are in conformity with all the applicable standards under EC Directives:

89/392/CEE

91/368/CEE

En concordancia con la Normativa de seguridad en pequeños aerogeneradores:
In accordance with the Normative of Security in Small wind turbines:

UNE-EN-61400-2

Juan y David Bornay, S.L.

Fdo. Juan Bornay Rico.

Landscape and objects that influence on wind turbines

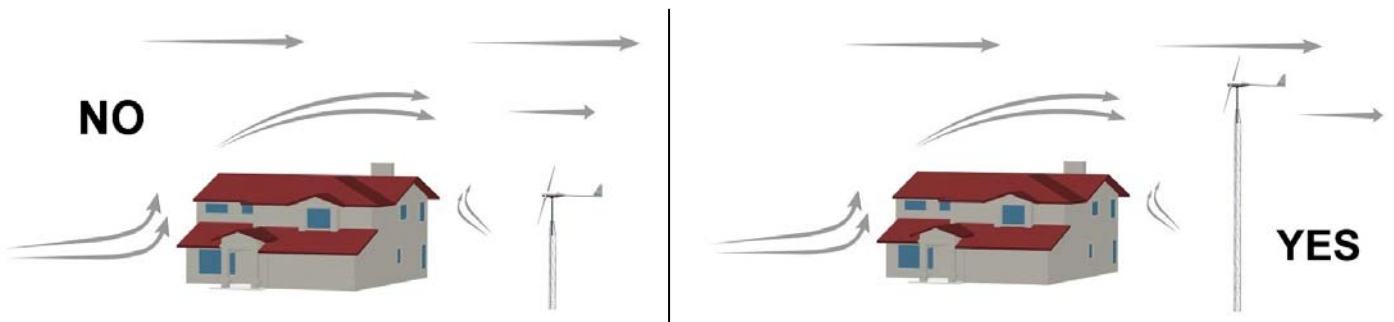

When the wind is eclipsed by the objects it finds in its way, it reduces its speed and results in turbulences. A wind turbine installed on the wrong place will not perform as it would in a non-influenced place.

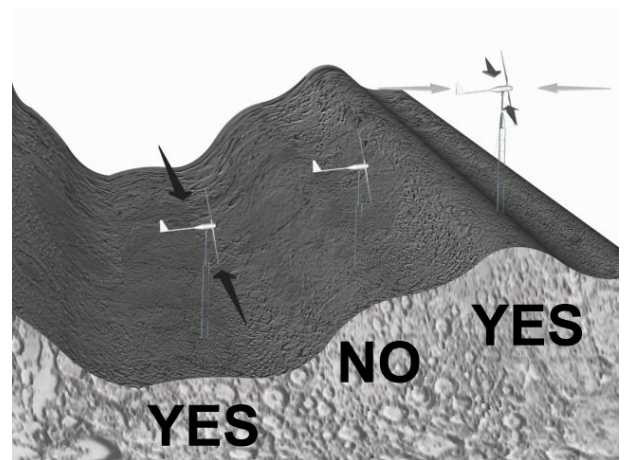
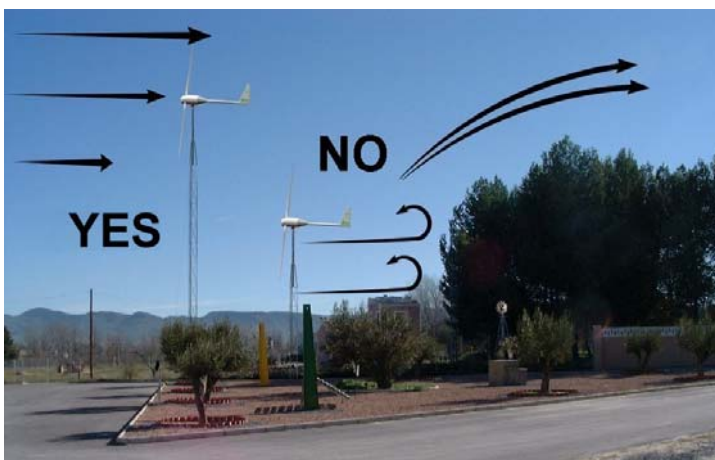

To maximize the performance of your wind turbine, it should be installed the farthest away possible from the obstacle and over a tower higher of this obstacle.

If the wind turbine is going to be installed in a valley, it should be done on the top where it will catch the wind from any direction, or on the bottom where the wind is canalized.

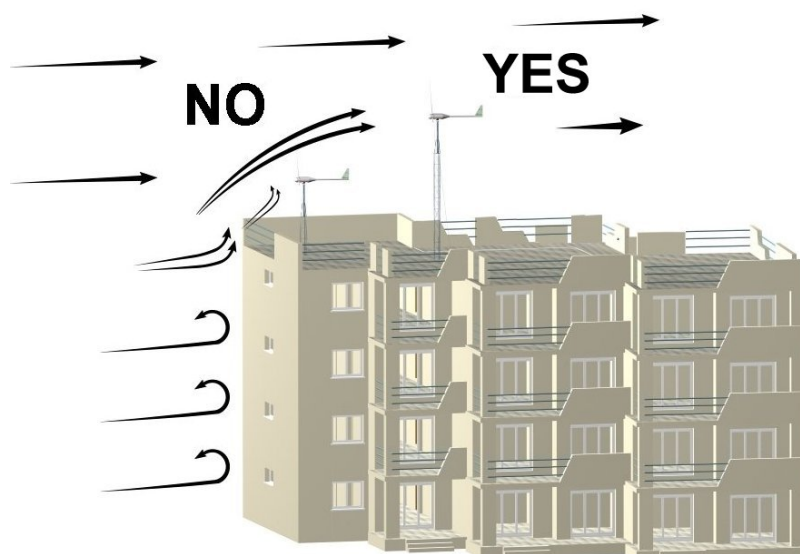

Warranty

Limited Warranty

Your new Incline wind turbine is guaranteed against any material defect. This warranty does not include other equipment or accessories that could be involved in the reparation of the wind turbine. The warranty does not include defects or damages produced by an inadequate use or installation of the product.

WARRANTY PERIOD – INCLIN WIND TURBINES

The warranty period for the InclIn wind turbines and their components is 24 months from date of original installation or 30 months from fabrication date.

INCLIN WIND TURBINES ACCESORIES

The warranty period for the InclIn accesories is 24 months from date of original installation or 30 months from fabrication date.

WARRANTY CONDITIONS

The warranty will only be valid if the annex warranty card is filled correctly.

The warranty includes replacement of defective pieces and job repair in our factory; the items to be repaired must be sent to our factory; the sender/owner of the defective piece will be responsible for all mailing charges.

The warranty excludes damage ports.

J.Bornay reserves the right to change pieces as we see fit.

Any wind turbine excluded from the warranty conditions will be repaired and sent back. These repair costs will be charged/billed.

MODEL	Customer
INCLIN 6000 neo	Full Name: _____
Serial Nº / Voltage	Address: _____ Nº _____
-----	C.P. _____ City _____
Installation date: ____/____/____	Province _____
	Telephone _____
	e-mail _____
Installer's stamp and signature	



Cut and send to J.Bornay – Apartado de Correos 116 – 03420 Castalla (Alicante) España